Series 31 Carriage Lane Receptacle

The Series 31 Carriage Lane receptacle comes equipped with a removable steel lid secured by a plastic-coated stainless steel cable, and a 20-gallon (91 litre) galvanized inner liner which sits in a black plastic outer liner. It is internally bolt-fastened to the ground.

GENERAL SPECIFICATIONS

Metal: Mild steel, wheel-abraded to bare metal, then precisely fabricated to final shape. The metal is first zinc primed then powder coated with polyester, electrostatically applied, and baked at high temperature to produce a mar-resistant finish.

OPTIONS

Lids: Standard, removable mild steel or rain-proof metal lid (shown in image) are available.

Side Door: R31-UBC models is equipped with a side access door to remove the liner.

Metal Colours: Make your choice from 26 standard paint colours. Or, for an additional charge, choose from one of over 160 custom paint colours. Standard colour chips and custom colour charts are available upon request.



R31-1

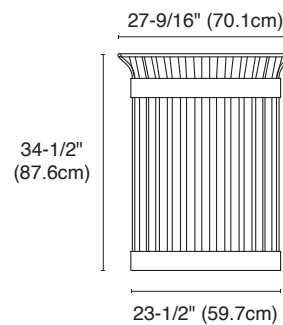

R31-1M5

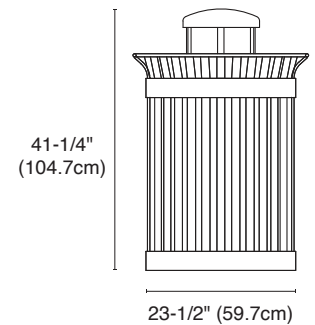

R31-UBC

